

# CU-FYUGP BSc Physics Honours

(2024 Admission)

## PHY2CJ101 ELECTRONICS- 1 (Semester – II)

### Major Practical Experiments-Lab Manual

*Prepared by*

**Dr. Nijo Varghese**

Member, UG Physics Board of Study, University of Calicut

Asst. Professor, Sacred Heart College(Autonomous), Chalakudy,

Thrissur Dist, Kerala. [www.sacredheartcollege.ac.in](http://www.sacredheartcollege.ac.in)

<b>Experiments</b>	<b>Page</b>
1. <a href="#">Study the I-V characteristics of diodes</a>	02
2. <a href="#">Zener diode characteristics and Regulator</a>	04
3. <a href="#">I-V Characteristics of Solar Cell</a>	06
4. <a href="#">Construction of the Half Wave Rectifier</a>	11
5. <a href="#">Construction of the centre tapped full wave rectifier</a>	14
6. <a href="#">Construction of the bridge rectifier</a>	16
7. <a href="#">Realize clipping and clamping circuits using diodes</a>	17

*(Revised on 19.01.2025. Check the link for the latest version -*

[https://drive.google.com/drive/folders/1utnySMzHeZrjmD\\_70nrlboyKhXwlALO9?usp=sharing](https://drive.google.com/drive/folders/1utnySMzHeZrjmD_70nrlboyKhXwlALO9?usp=sharing) )

## Experiment 1. Study the I-V characteristics of diodes

**Aim:** To study the I-V characteristics of Ge, Si diodes, LEDs and photodiode.

**Apparatus:** ExpEYES, IN4001. OA79 diodes, Different colour LEDs.

### Principle:

Refer Principles of Electronics by V K Mehtha and Rohith Mehtha (Book 1)

### Procedure:

#### Forward characteristics

- <https://expeyes.in/experiments/electronics/diodeIV.html>
- Select **Experiments > Electronics > Diode VI Characteristics > RECORD DATA.**
- The terminal PV1(Programmable Voltage source) provides the variable power supply. The voltage across the diode is measured using input terminal A1. ExEYES work out the current through the diode as  $(PV1-A1)/R1$ . Connect  $R1= 1k\Omega$  between PV1 and A1 and the diode p-region to A1 and n region to GND.
- Tap START to trace the I-V curve. Replace a different diode and START again to compare the curves.
- Screenshot the curves. Share -> CSV Data to export the data for further analysis.

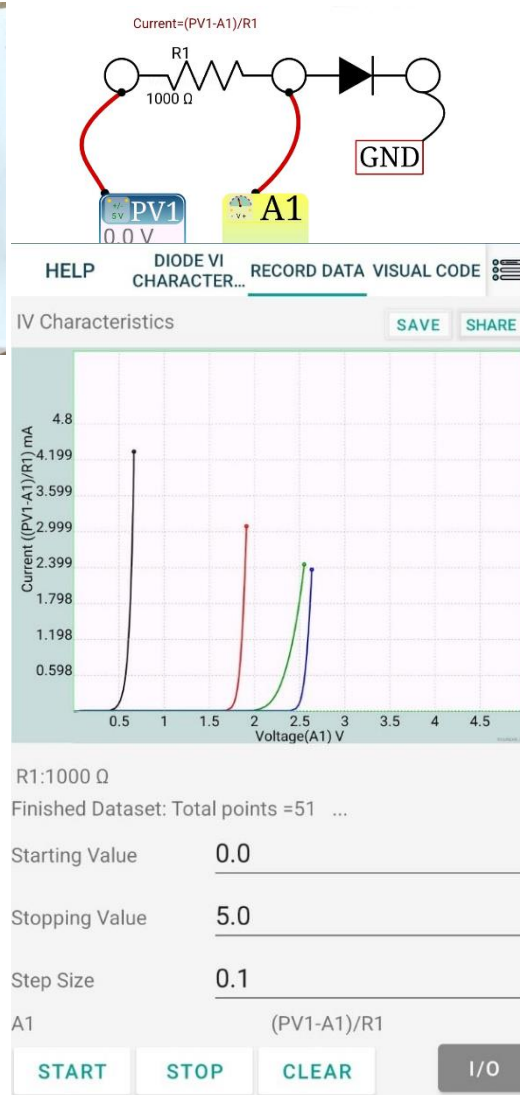
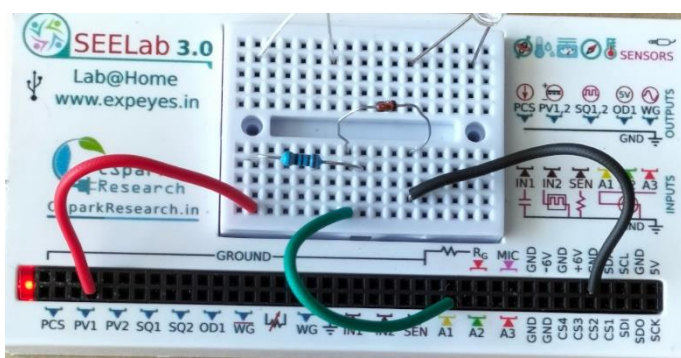

### Observations:

The forward characteristics of Silicon diode(black), red, green and blue LEDs are shown in the figure.

The turn on voltage of the LED increases with the frequency of the light emitted by the LED.

Turn on voltage of LEDs

RED – 1.8V

Green – 2.2V

Blue – 2.6 V

## Comparison between Silicon and Germanium diodes

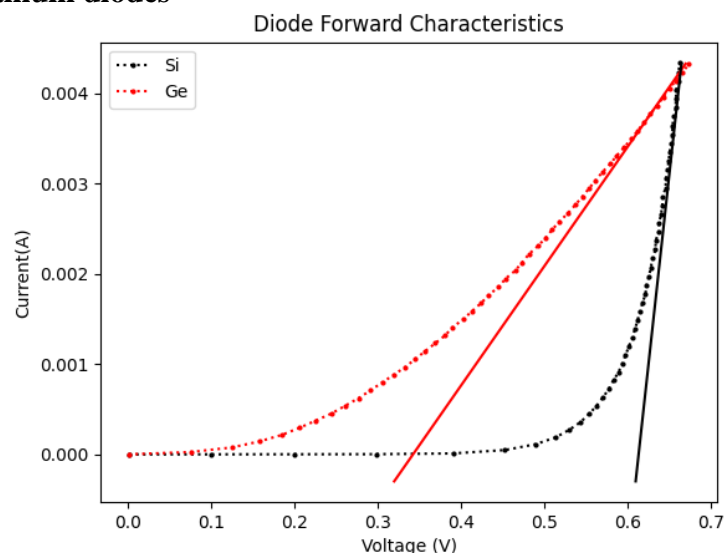
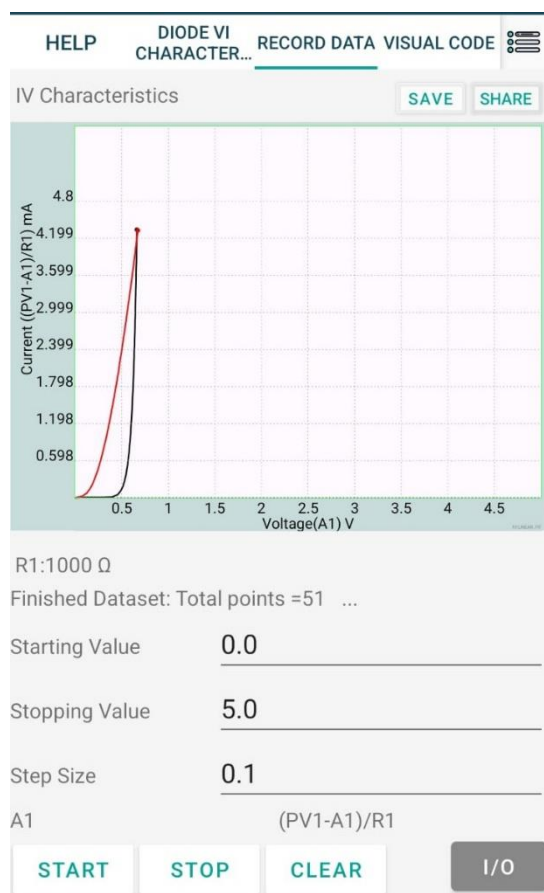

(Left) Screenshot of the forward characteristics of Silicon (black) and Germanium (red) diodes

(Right) exported data plotted using python.

The germanium diode has a lower forward voltage drop (around 0.3V) compared to a silicon diode (around 0.61V). The Silicon diodes are more widely used because of their higher stability and higher breakdown voltage.

Alternatively, select **Experiments > Electronics > IV Characteristics > RECORD DATA** to study both forward and **reverse characteristics**.

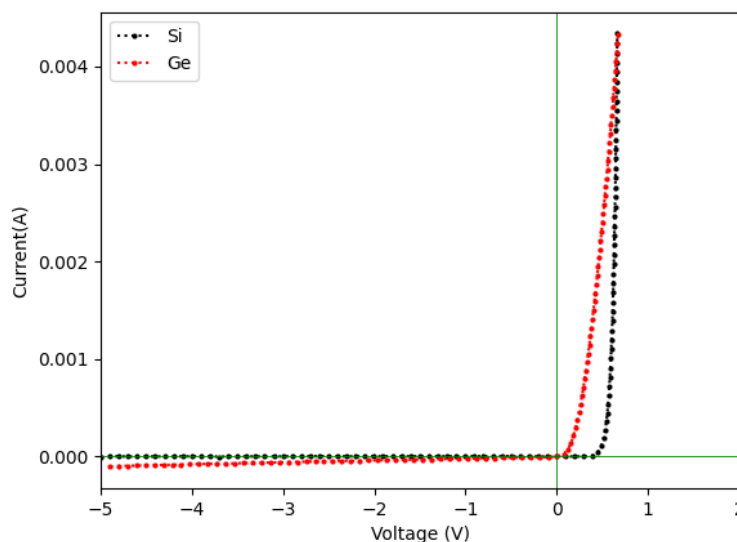
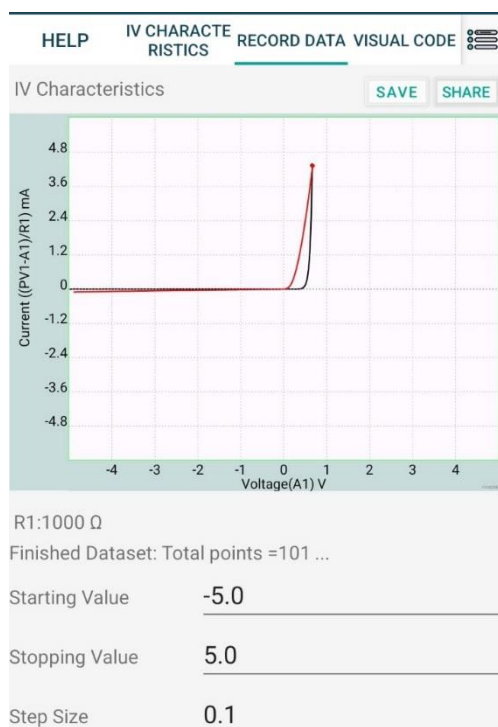

Compared to a silicon diode, a germanium diode has a significantly higher reverse saturation current, meaning it allows a larger current to flow in the reverse bias direction.

**Result:** IV characteristics of Ge, Si diodes, LEDs and photodiode were studied.

## Experiment 2. Zener diode characteristics and Regulator

**Aim:** To study the characteristics of Zener diode and construct a voltage regulator.

**Apparatus:** ExpEYES, 3V, 5V Zener diodes.

### Theory:

Refer Principles of Electronics by V K Mehtha and Rohith Mehtha (Book 1)

A Zener diode is a specially designed semiconductor diode that acting as normal diode while forward biasing but allows current to flow in the reverse direction when the voltage exceeds a specific value known as the **Zener breakdown voltage**. It operates based on the principle of breakdown in a highly doped p-n junction. When a diode is heavily doped, its depletion region will be narrow. When a high reverse voltage is applied across the junction, there will be very strong electric field at the junction. And the electron hole pair generation takes place. Thus, heavy current flows. This is known as zener breakdown

Zener diodes are widely used for voltage regulation, protection circuits, and as reference elements in electronic devices, maintaining a stable output voltage despite variations in input voltage or load conditions.

### Procedure:

Forward characteristics.

- <https://expeyes.in/experiments/electronics/zenerIV.html>
- Select **Experiments > Electronics > Zener Diode Characteristics > RECORD DATA**.
- The terminal PV1(Programmable Voltage source) provides the variable power supply. The voltage across the diode is measured using input terminal A1. ExEYES work out the current through the diode as  $(PV1-A1)/R1$ . Connect  $R1= 1k\Omega$  between PV1 and A1 and the diode p-region to A1 and n region to GND.
- Tap START to trace the IV curve.

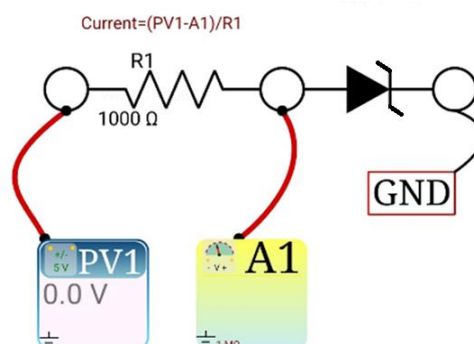
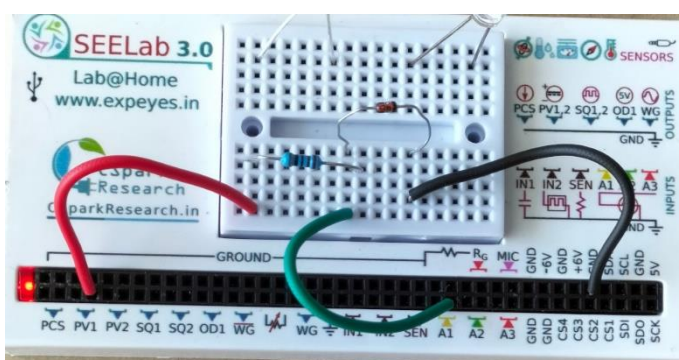

### Observations:

The I-V characteristic of Zener diode indicates that characteristic of Zener diode in forward bias is same as PN junction diode. In reverse bias, a negligible constant current flow through the Zener diode but the current becomes abruptly large at Zener voltage. The I-V characteristics two different diode are shown in the figure. The breakdown voltages are 3V (red curve) and 5V (black curve).

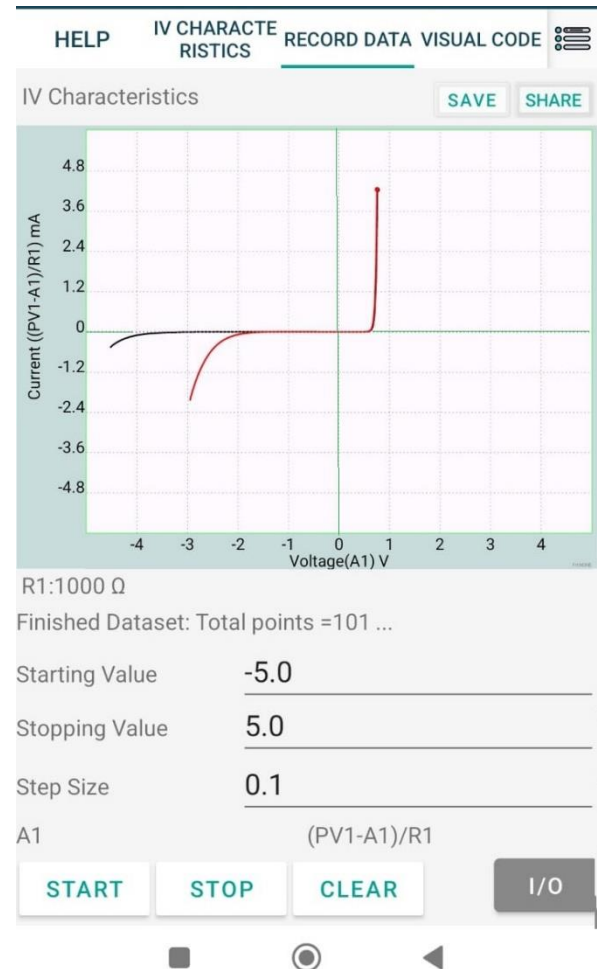

### Construction of Voltage Regulator

### Experiment 3. V-I Characteristics of Solar Cell

**Aim:** To Study the I-V characteristics of solar cell and find the open circuit voltage, short circuit current and maximum power output.

**Apparatus:** Solar cell (<5V), 1kOhm resistance, ExpEYES, sunlight or other light source.

**Principle:**

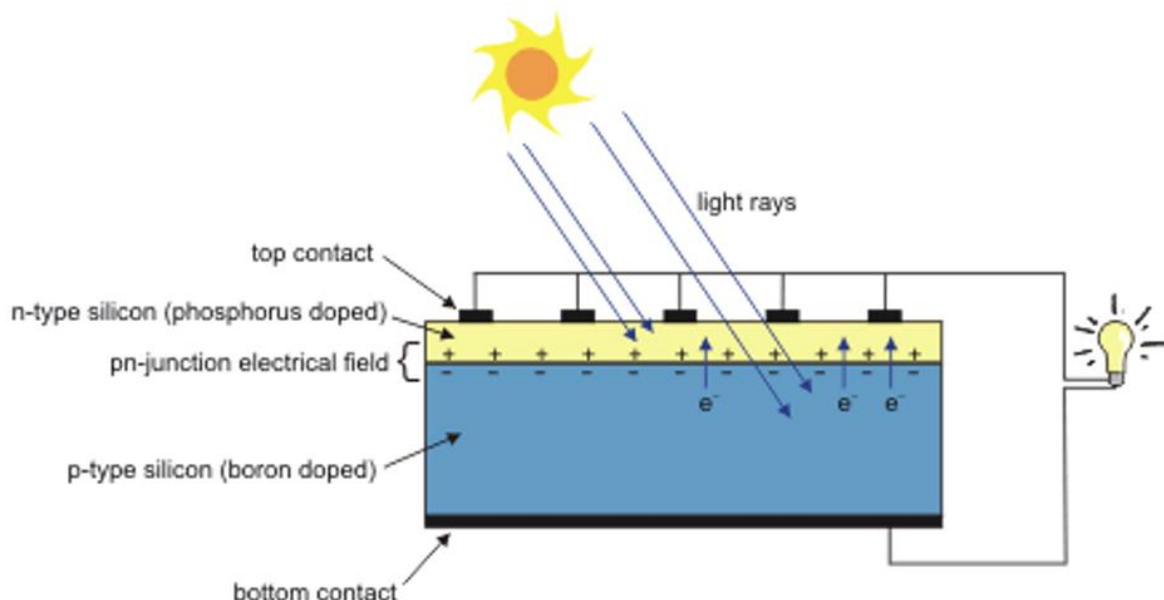

Solar cells are basically a p-n junction, which converts sunlight (solar energy) into electrical energy. When a solar cell is illuminated, the photons incident on the cell generate electron-hole pairs. By diffusion in the material the electron and holes reach the junction. At the junction the barrier field separates the positive and negative charges carriers. Under the action of the electric field, the electrons (minority carriers) from p region are swept into n region. Similarly, the holes from n region are swept into p region. It leads to an increase in the number of holes on the p side and of the electrons on the n side of the junction. The accumulation of charges on the two sides of the junction produces an emf, which is called a photo emf. The photo emf is known as open circuit voltage. It is proportional to the illumination ( $W/m^2$ ) and on the size of the illuminated area. When an external circuit is connected across the solar cell terminals, the minority carriers return to their original sides through the external circuit, causing the current to flow through the circuit. Thus the solar cell behaves as a battery with n side as the negative terminal and p side as positive terminal. The photo emf or voltage can be measured with a voltmeter.

A V-I characteristic of a photovoltaic cell is shown in the figure. If the solar cell is not exposed to light, it behave like a normal pn junction diode(black curve). When illuminated, an emf is generated and the forward characteristics curve shifts down to the fourth quadrant of the graph (red curve). The e.m.f is. generated by the photo-voltaic cell in the open circuit, i.e. when no current is drawn from it is denoted by  $V_{OC}$  (V-open circuit). This is the maximum value of e.m.f.. When a high resistance is introduced in the external circuit a small current flow through it and the voltage decreases. The voltage goes on falling and the current goes on increasing as the resistance in the external circuit is reduced. When the resistance is reduced to zero the current rises to its maximum value known as saturation current and is denoted as  $I_{SC}$ , the voltage becomes zero.

*Prepared by Dr. Nijo Varghese, Asst. Professor, Sacred Heart College(Autonomous), Chalakudy*

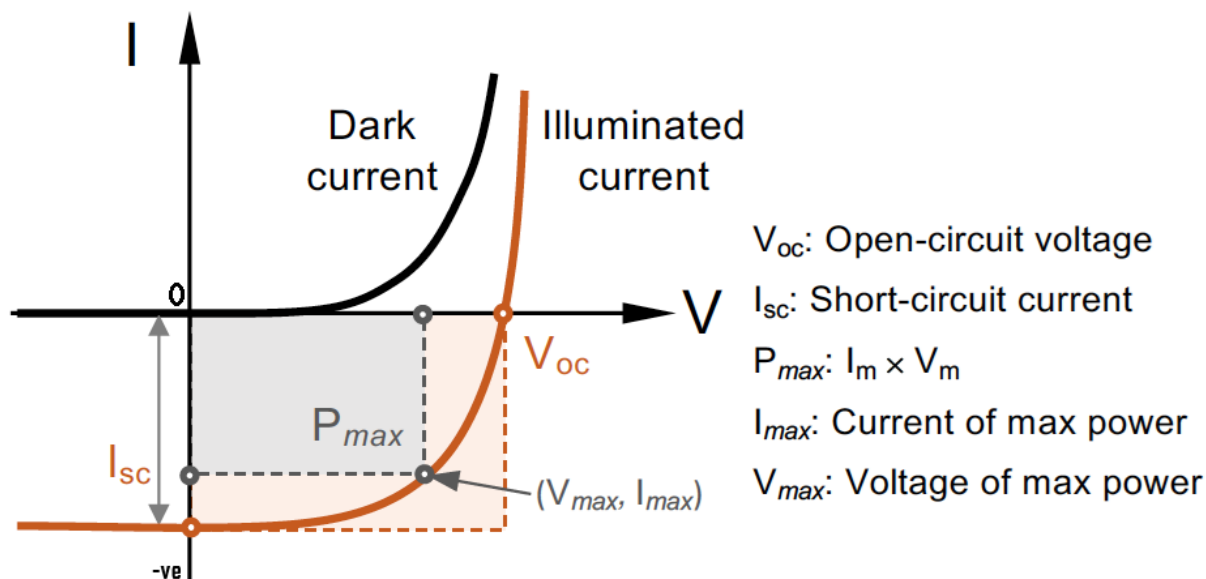

The product of open circuit voltage  $V_{OC}$  and short circuit current  $I_{SC}$  is known as ideal power.

$$\text{Ideal Power} = V_{OC} \times I_{SC}$$

The maximum useful power is the area of the largest rectangle that can be formed under the V-I curve. If  $V_m$  and  $I_m$  are the values of voltage and current under this condition, then

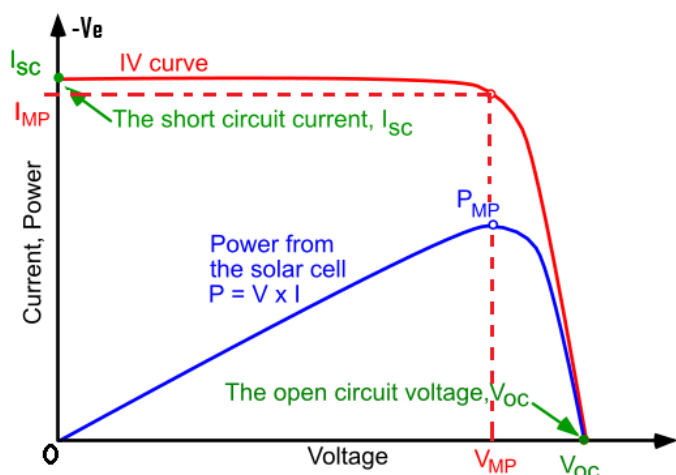

$$\text{Maximum useful power} = V_m \times I_m$$

$P_{max}$  can also be found by plotting voltage Vs power. The ratio of the maximum useful power to ideal power is called the fill factor

$$\text{Fill factor} = \frac{V_m \times I_m}{V_{OC} \times I_{SC}}$$

If the value of FF is high, the cell is better quality.

## Procedure

- Reference: <https://expeyes.in>
- Select **Experiments > Electronics > IV Characteristics > RECORD DATA.**
- The terminal PV1 (Programmable Voltage source) provides the variable power supply. The voltage across the solar cell is measured using input terminal A1. ExEYES work out the current through the cell as  $(PV1-A1)/R1$ . Connect  $R1 = 1k\Omega$  between PV1 and A1 and the solar cell positive to A1 and negative to GND.
- To measure the dark current characteristics, first mask the solar cell from light and tap START to trace (black) the IV curve.

- Illuminate the solar cell with sunlight or any other white light source and tap START again to trace (red) the illuminated current.
- Screenshot the curves. Share -> CSV Data to export the data to get the values of  $V_{oc}$ ,  $I_{sc}$  and the power calculation.
- Calculate power, plot V vs Power to find the  $P_{max}$ ,  $V_m$  and  $I_m$ .

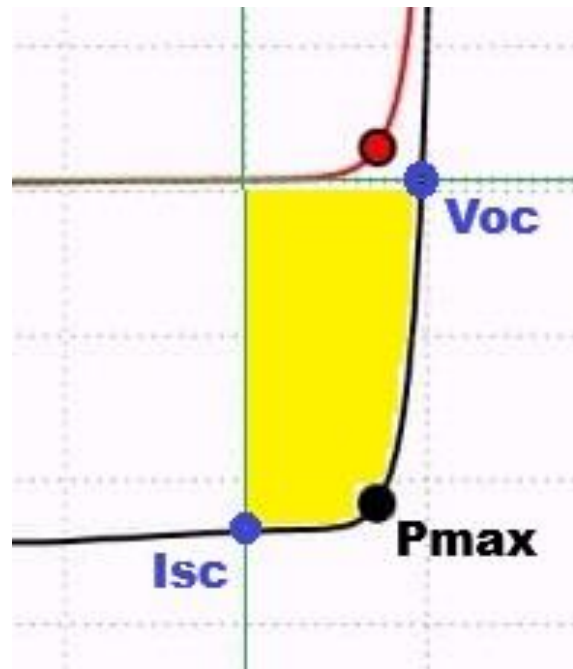
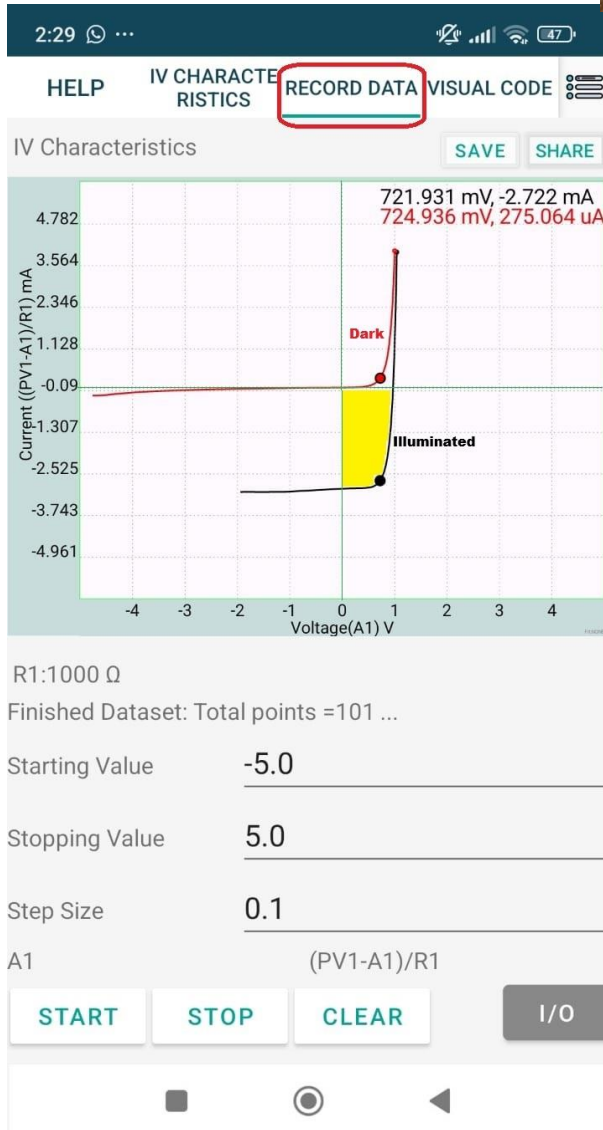
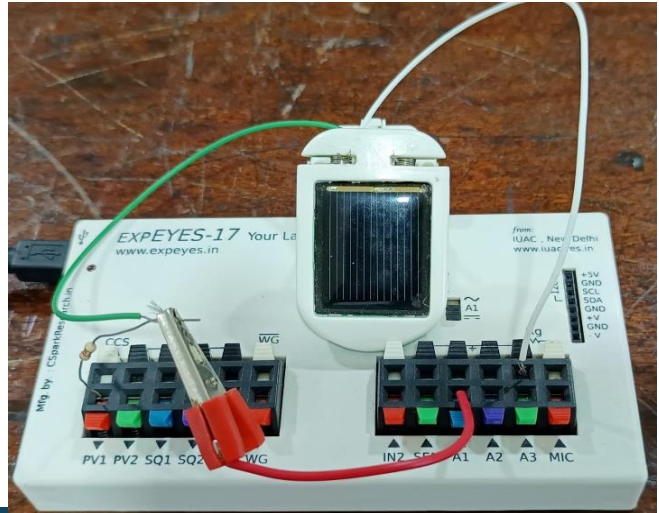
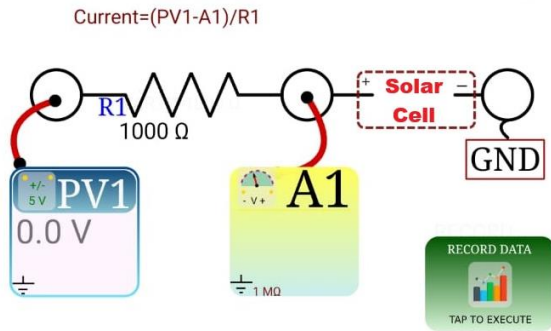



### Observations:

Tabulate the IV characteristics of solar cell under illuminated condition (Only the data of fourth quadrant is needed. i.e, V is positive and I is negative) and calculate the power.

Voltage (V)	Current (A)	Power = V x I	Voltage (V)	Current (A)	Power = V x I
-0.03923	-0.00296	0.00012	0.88423	-0.00178	-0.00158
0.05444	-0.00295	-0.00016	0.89125	-0.00169	-0.00151
0.14887	-0.00295	-0.00044	0.89851	-0.00160	-0.00144
0.24555	-0.00295	-0.00072	0.90452	-0.00150	-0.00136
0.34298	-0.00294	-0.00101	0.91053	-0.00141	-0.00128
0.43765	-0.00294	-0.00129	0.91479	-0.00131	-0.00120
0.52156	-0.00292	-0.00152	0.92205	-0.00122	-0.00113
0.59319	-0.00289	-0.00172	0.92656	-0.00113	-0.00104
0.64604	-0.00285	-0.00184	0.93107	-0.00103	-0.00096
0.68887	-0.00279	-0.00192	0.93508	-0.00094	-0.00087
0.72193	-0.00272	-0.00197	0.93984	-0.00084	-0.00079
<b>0.74973</b>	<b>-0.00265</b>	<b>-0.00199</b>	0.94384	-0.00074	-0.00070
0.77152	-0.00257	-0.00198	0.94685	-0.00065	-0.00061
0.79206	-0.00249	-0.00197	0.95061	-0.00055	-0.00052
0.80884	-0.00241	-0.00195	0.95486	-0.00045	-0.00043
0.82287	-0.00232	-0.00191	0.95862	-0.00036	-0.00034
0.83639	-0.00224	-0.00187	0.96138	-0.00026	-0.00025
0.84791	-0.00215	-0.00182	0.96388	-0.00016	-0.00016
0.85818	-0.00206	-0.00177	<b>0.96739</b>	-0.00007	-0.00007
0.86695	-0.00197	-0.00171	0.97014	0.00003	0.00003
0.87722	-0.00188	-0.00165	0.97415	0.00013	0.00012

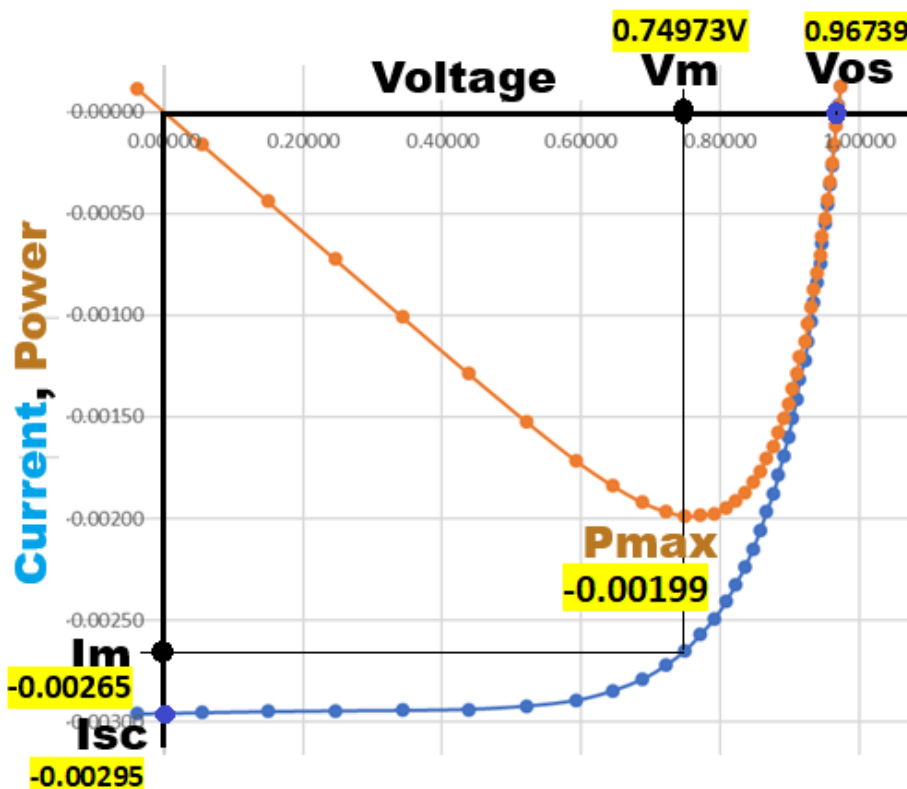

$$\text{Ideal Power} = V_{OC} \times I_{SC} = 0.96739 \times 0.00295 = 0.00285 \text{ W}$$

$$\text{Maximum useful power} = V_m \times I_m = 0.74973 \times 0.002667 = 0.00199 \text{ W}$$

$$\text{Fill factor} = \frac{V_m \times I_m}{V_{OC} \times I_{SC}} = \frac{0.00199}{0.00285} = 0.702$$

### Result

The V-I characteristics of solar cell is studied.

Maximum useful power = **0.00199 W**

Fill factor = **0.702**

### Note:

The efficiency of the solar cell  $\eta = \frac{P_{max}}{P_{in}} \times 100$

The incident light power,  $P_{in} = \text{Incident radiation flux (in W/m}^2\text{)} \times \text{Area of the solar cell.}$

We need a standardized light source to calculate the efficiency. The solar constant (the amount of solar energy that reaches a unit area on Earth, perpendicular to the sun's rays) = approximately 1370W/m<sup>2</sup>. On a clear day, when the Sun is at zenith, we can approximate the solar light intensity as 1000W/m<sup>2</sup>.

### Experiment 4. Construction of the Half Wave Rectifier

**Aim:** To Construct a half wave rectifier, observe the output waveform and without filter and with filter capacitors of four different values. To measure DC voltage, DC current, ripple factor with and without filter capacitor.

**Apparatus:** Transformer (6V-0-6V), Diode, 1N4001, Capacitors- 4.7uF, 10uF, 47uF, 100uF, Decade Resistance Box, Digital Multimeter/CRO/ExpEYES.

**Principle:**

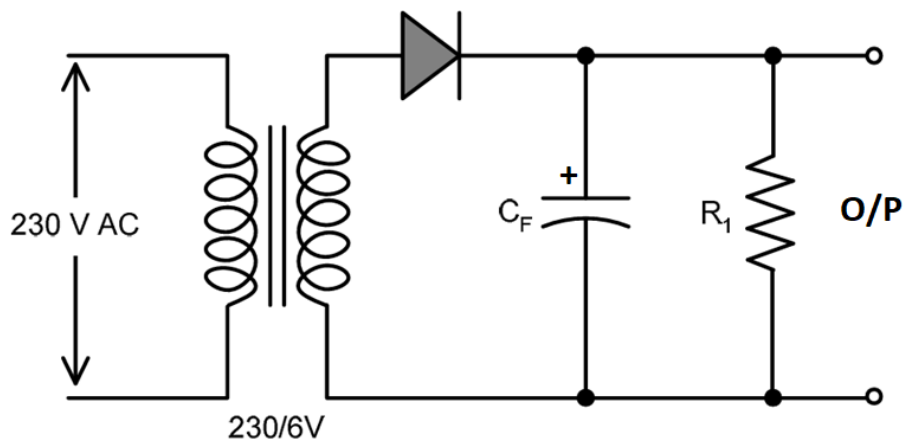

The a.c. supply to be rectified is applied in series with the diode and load resistance  $R_L$ . Generally, a.c. supply is given through a transformer. The a.c. voltage across the secondary winding  $AB$  changes polarities after every half-cycle. During the positive half-cycle of input a.c. voltage, end  $A$  becomes positive *w.r.t.* end  $B$ . This makes the diode forward biased and hence it conducts current. During the negative half-cycle, end  $A$  is negative *w.r.t.* end  $B$ . Under this condition, the diode is reverse biased and it conducts no current. Therefore, current flows through the diode during positive half-cycles of input a.c. voltage only ; it is blocked during the negative half-cycles. In this way, current flows through load  $R_L$  always in the same direction. Hence d.c. output is obtained across  $R_L$ . It may be noted that output across the load is pulsating d.c.

The peak value of output voltage is less than the peak value of input ac voltage by 0.6V, because of the voltage drop across the diode

These pulsations in the output are further smoothed with the help of *filter circuits*.

A high value capacitor  $C$  is connected in shunt with the load resistance  $R_L$ . Capacitor charges to peak voltage  $V_m$  when the half cycle appears at the output. After the peak value is passed, the capacitor discharges through the load resistor slowly since the diode is reverse biased by the capacitor voltage. Before the capacitor voltage drops substantially, next our put cycle arrives and the capacitor recharges to peak.

The output frequency of a half-wave rectifier is equal to the input frequency (50 Hz).

Ripple factor is calculated by using the formulae

$$\text{Without Filter: } r = \frac{\text{ac output voltage}}{\text{dc output voltage}}$$

$$\text{With Filter: } r = \frac{1}{2\sqrt{3}fCR}$$

## WAVEFORMS

Typical waveforms of half wave rectifier without filter and with filter are shown in the figure below

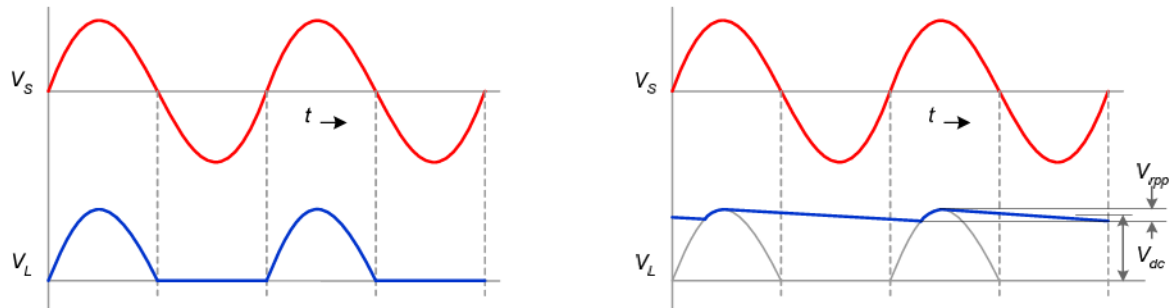

### Observations:

Input ac voltage = .....V

### Without Filter:

$R_L (\Omega)$	O/P voltage (V)		Ripple Factor, $r = \frac{V_{ac}}{V_{dc}}$
	$V_{ac}$	$V_{dc}$	
100			
500			
1000			
1500			
2000			
		Mean r	

### With Filters:

Load resistance,  $R_L = 100 \Omega$

Capacitance, C ( $\mu F$ )	O/P voltage (V)		Ripple Factor, $r = \frac{V_{ac}}{V_{dc}}$
	$V_{ac}$	$V_{dc}$	
4.7			
10			
47			
100			

### Result

Half wave rectifier is constructed, wave forms are observed and calculated the ripple factor with and without filter.

## To observe the wave form using ExpEYES

- Reference: <https://expeyes.in/experiments/electronics/halfwave.html>
- Select Experiments > Electronics> Half Wave Rectifier.
- The terminal WG provides the AC signal and the oscilloscope channels A1 and A2 measures the input (A1, black) and the output (A2, red) voltages. Make the connections as shown in the figure.

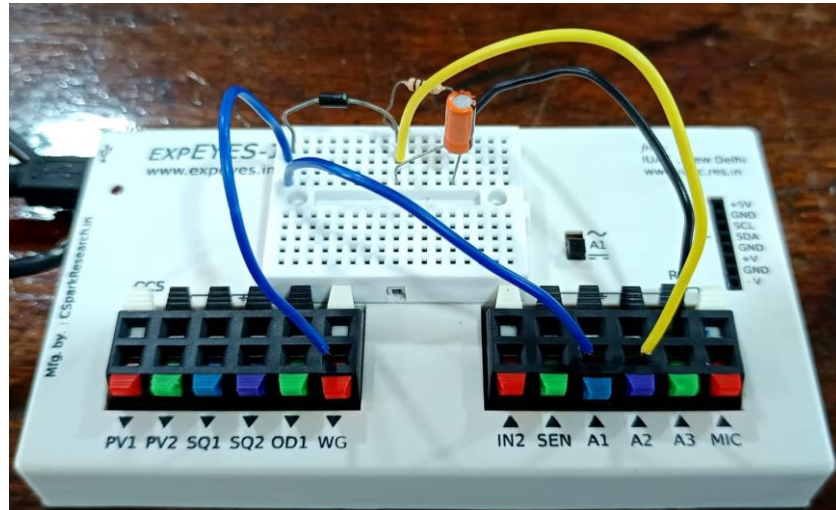

Waveform without filter capacitor. The output amplitude is lower because of the voltage drop across the diode

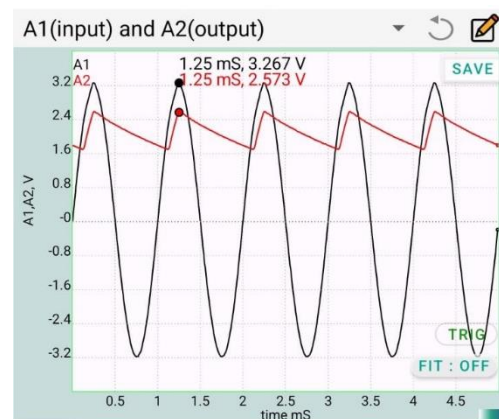
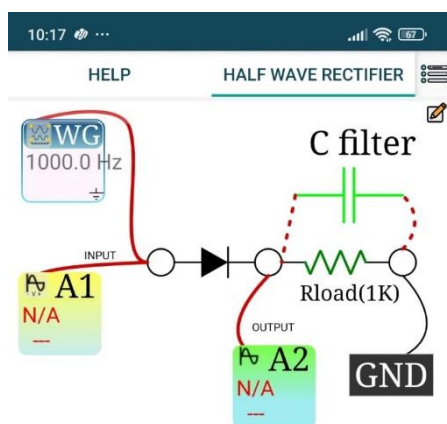

The output after adding a 1μF capacitor for filtering (top) and 47μF (bottom). With increasing RC value, the ripple reduces.

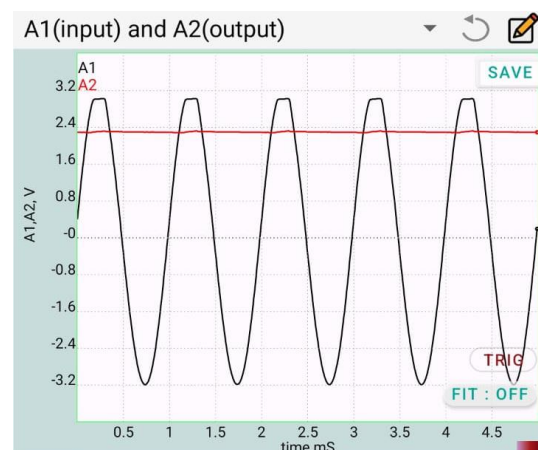
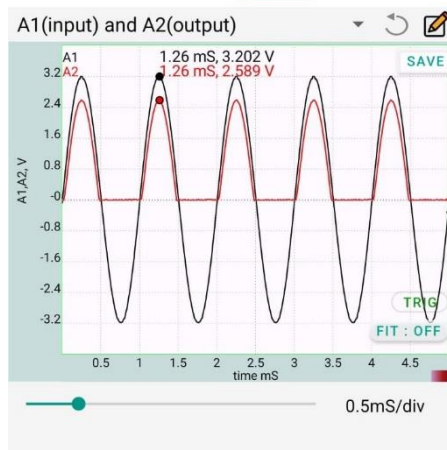

### Experiment 5. Construction of the centre tapped full wave rectifier and regulated power supply.

**Aim:** To Construct a full wave rectifier, observe the output waveform and without filter and with filter capacitors of four different values. To measure DC voltage, DC current, ripple factor with and without filter capacitor. Construct 5V/12V regulated power supply using 78XX IC

**Apparatus:** Transformer (6V-0-6V), Diodes 1N4007, Capacitors- 4.7uF, 10uF, 47uF, 100uF, 0.01uF, Decade Resistance Box, 7805 regulator IC, Digital Multimeter/ CRO/ ExpEYES.

#### Principle:

The circuit of a center tapped full wave rectifier uses two diodes D1 and D2. During the positive half cycle of the secondary voltage, diode D1 is forward biased and D2 is reverse biased. Diode D1 conducts, and current flows through the load resistor RL. During the negative half cycle, D2 becomes forward biased and D1 is reverse biased. Now D2 conducts, and current flows through RL. Thus, during both half cycles, a unidirectional current is obtained. The main difference between full wave and half wave rectification is that a full wave rectifier allows unidirectional current during the entire 360 degrees of the input signal, whereas a half wave rectifier does so only during one half cycle (180 degrees).

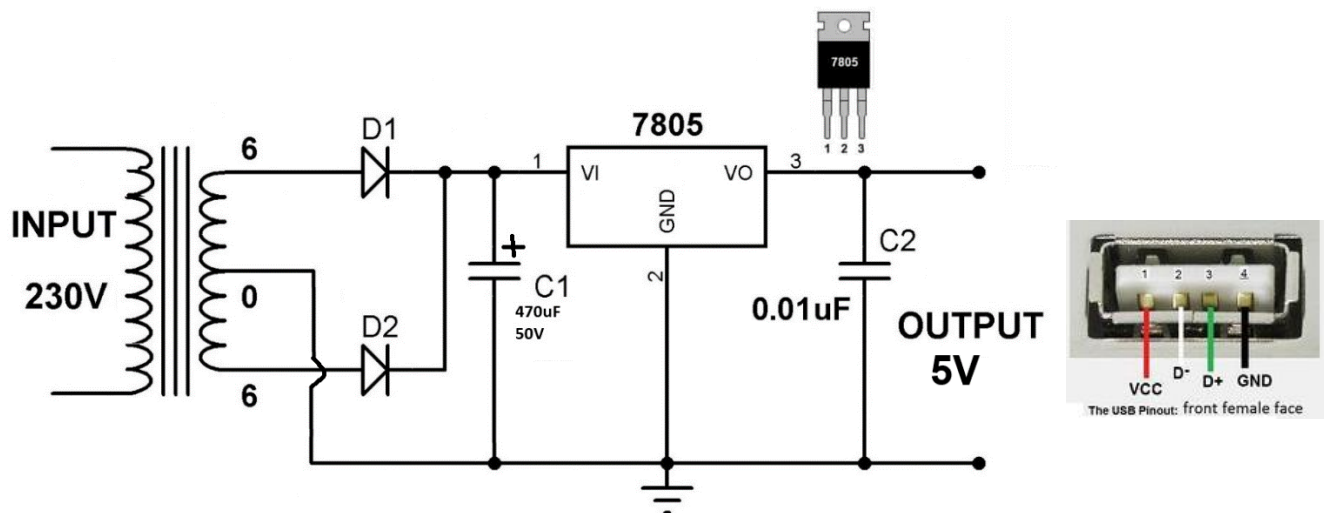

#### Procedure:

First construct the full wave rectifier without the regulator IC part.

*Observation tabulation columns are the same as that of Half wave rectifier.*

#### 7805 Voltage regulator

7805 is a simple low cost Voltage regulator is a three terminal device that provides a fixed output voltage of 5V (up to 1.5A) and can handle an input voltage of 7V to 35V.

To use 7805 voltage regulator connect the input voltage to Vin pin (1), the ground to GND pin(2) and Vout pin (3) gives the stable 5V.

AC input voltage	DC output voltage	Regulated DC output voltage

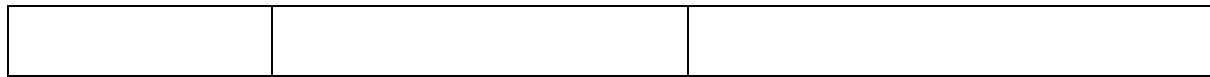

**Optional:** Regulated 5V may be used for mobile charging using a type A USB female socket.

### To observe the wave form using ExpEYES

- Reference: <https://expeyes.in/experiments/electronics/fullwave.html>
- Select Experiments > Electronics> Half Wave Rectifier.
- Fullwave rectifier require two AC inputs having 180 degree phase difference. Generally, this experiment is done using a center tapped transformer. In this case WG and WGbar provides the inputs. The inputs are monitored by the scope channels A1(black) and A2(red). The output is connected to A3(green). Make the connections as shown in the figure

Waveform without filter capacitor. The output amplitude is lower because of the voltage drop across the diode

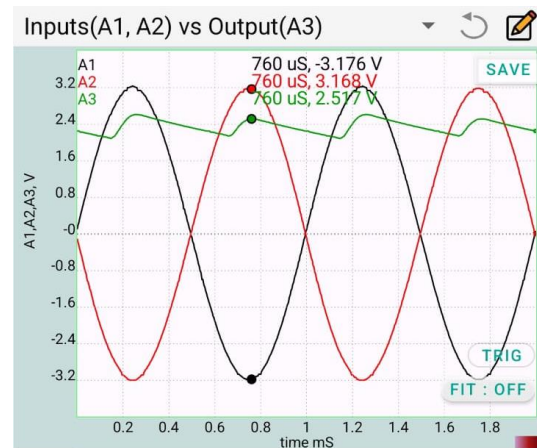
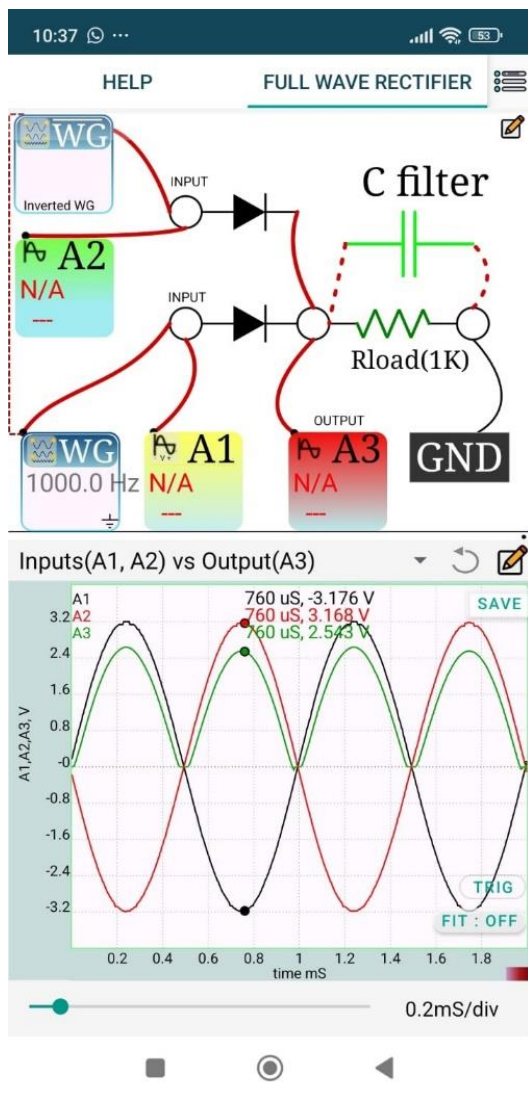

The output after adding a 1uF capacitor for filtering(top) and 47uF (bottom). With increasing RC value, the ripple reduces.

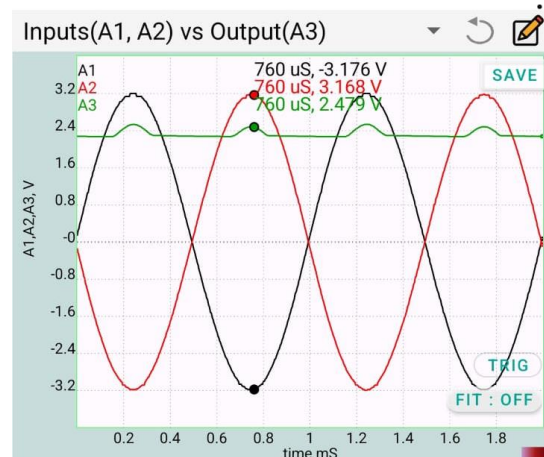

## Experiment 6. Construction of the bridge rectifier

**Aim:** To Construct a bridge rectifier, observe the output waveform and without filter and with filter capacitors of four different values.

**Apparatus:** Transformer (6V-0-6V), Diodes 1N4007, Capacitors- 4.7uF, 10uF, 47uF, 100uF, 0.01uF, Decade Resistance Box, Digital Multimeter/ CRO/ ExpEYES.

### Principle:

A bridge rectifier converts alternating current (AC) to direct current (DC) using four diodes—D1, D2, D3, and D4—arranged in a bridge configuration. During the positive half-cycle of the AC input, diodes D1 and D2 conduct, allowing current to flow from the input through D1, across the load resistor, and back through D2 to the source. In the negative half-cycle, diodes D3 and D4 conduct, directing current from the input through D3, across the load resistor in the same direction as before, and back through D4 to the source. This arrangement ensures that the current across the load always flows in the same direction, producing a pulsating DC output.

The filter capacitor, connected across the load, charges to the peak voltage during the conduction phase and discharges slowly when the diodes are not conducting, filling the gaps in the rectified waveform. This reduces the ripple and provides a smoother DC output.

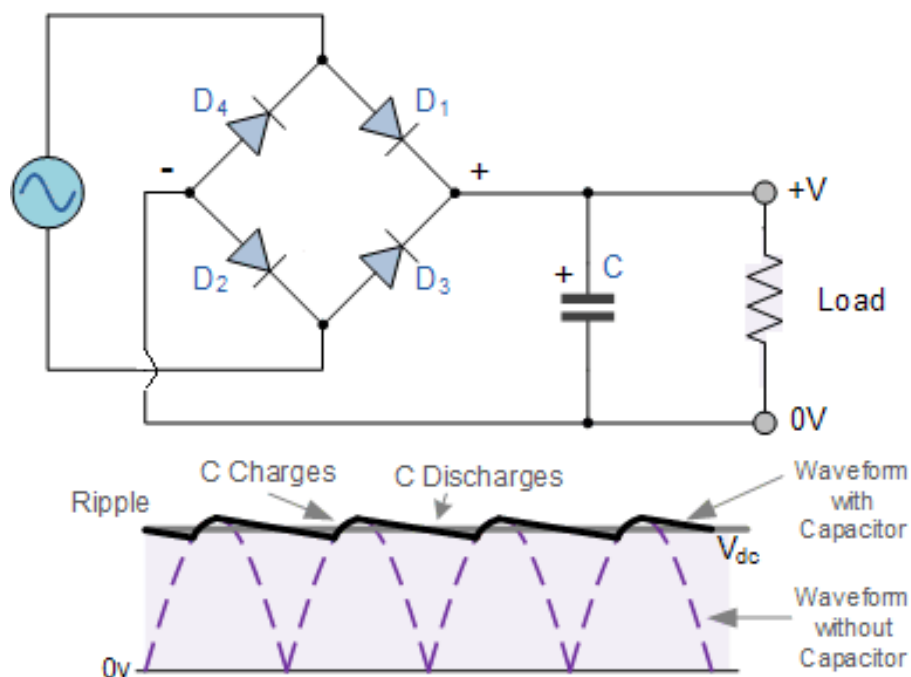

### Procedure:

Same as that of Experiment 5.



## Experiment 7. Realize clipping and clamping circuits using diodes

**Aim:** To Construct circuits using diodes to clip the top, or bottom, or both of a waveform at a particular dc level.

Construct positive and negative clamper circuits and analyse the waveforms using CRO/ExpEYES.

**Apparatus:** ExpEYES, 1kOhm, IN4001, Zener diodes(<3V).

### Theory:

#### Clipping Circuits

A diode clipping circuit is used to limit the voltage of a signal to a certain predefined level, effectively "clipping" the parts of the waveform that exceed this level. These circuits are widely used in signal processing to prevent distortion, overvoltage protection, and waveform shaping. **Diode** act as the main element for clipping.

**Positive Clipping:** The diode is oriented to conduct for positive half-cycles of the input signal. For voltages greater than the diode's threshold (e.g., 0.7V for silicon), the diode conducts and clips the signal to the threshold level. The resistor limits the current through the diode, protecting it from damage.

**Negative Clipping:** The diode is oriented to conduct for negative half-cycles of the input signal. For voltages less than the diode's reverse threshold, the diode conducts and clips the signal to the negative threshold.

**Clipping with Reference Voltage:** A reference voltage is added in series with the diode to set a custom clipping level. The output voltage is clipped at the reference voltage plus the diode's forward voltage.

$$\text{Forward Clipping Voltage: } V_{\text{clip}+} = V_{\text{ref}} + V_f$$

$$\text{Reverse Clipping Voltage: } V_{\text{clip}-} = -(V_{\text{ref}} + V_f)$$

Where:  $V_{\text{ref}}$  is the reference voltage (if any) and  $V_f$  is the forward voltage of the diode.

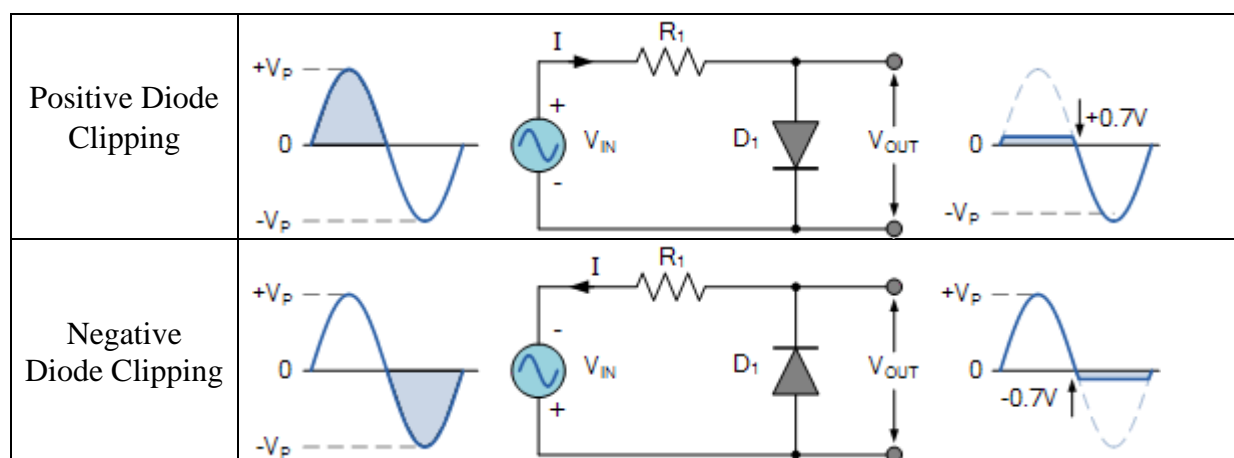

Clipping of Both Half Cycles	
(Positive) Biased Diode Clipping	
Zener Diode Clipping	
Full Wave Zener Diode Clipping	

### Procedure:

- <https://expeyes.in/experiments/electronics/clipping.html>
- Select **Experiments > Electronics > Clipping circuit using Diode**.
- The AC signal from WG is connected to a PN junction through a 1 kOhm resistor. Other end of the PN junction is connected to the DC supply PV1. The input is monitored by A1 and the signal after the resistor by A2. The AC signal gets clipped at the diode drop ( $\sim 0.7$  volts) when PV1 is set to zero.
- The clipping level changes with the value of PV1.
- As the AC signal from WG is 3V use a Zener with break down voltage  $< 3V$ .
- Screenshot and share the wave forms.

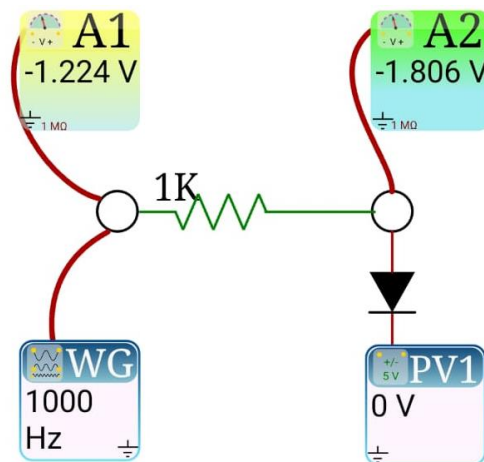

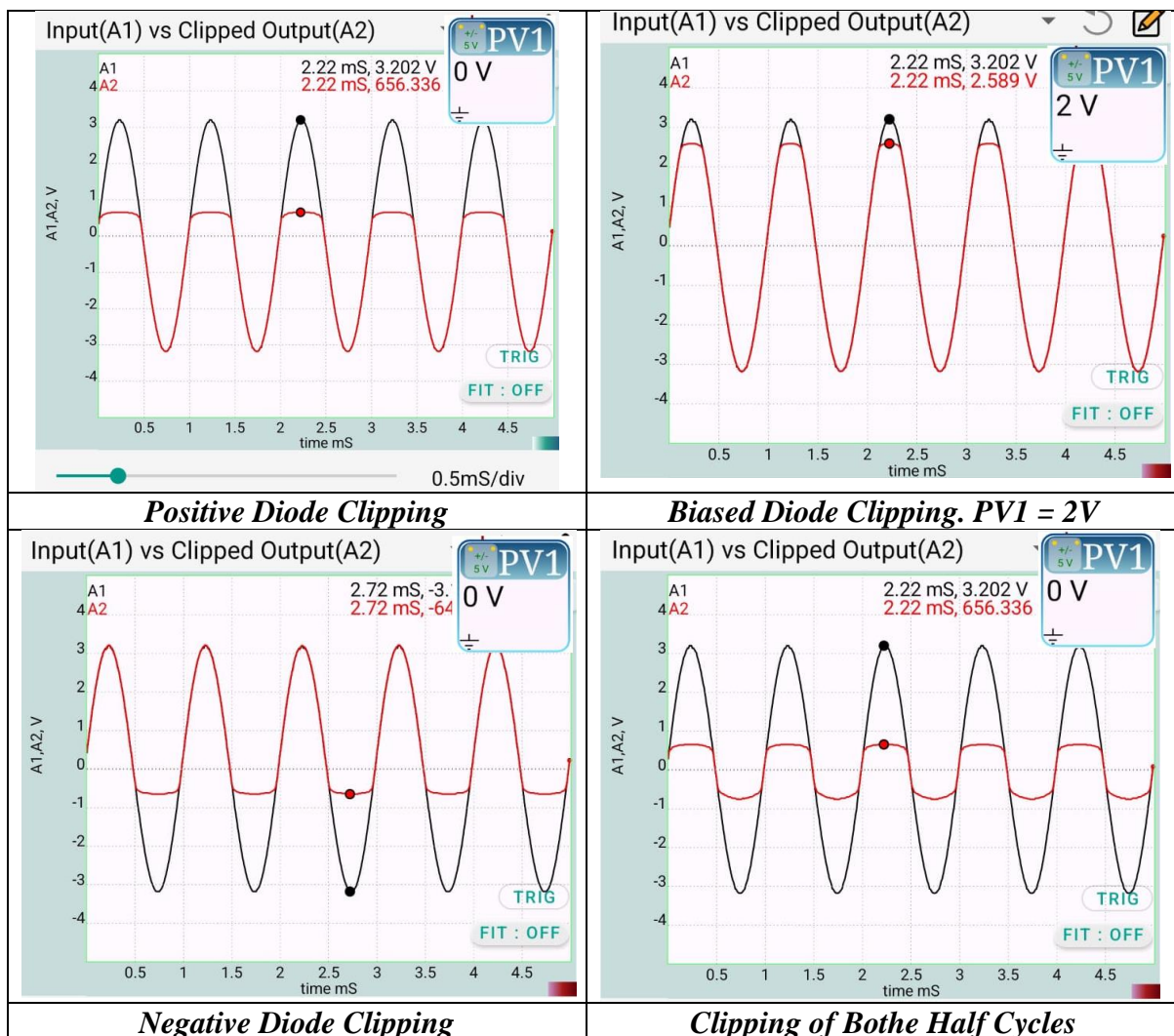

## Clamping Circuits

A **clamping circuit** is an electronic circuit designed to shift the DC level of a signal without altering its shape. This is accomplished by adding a DC voltage to the input signal, effectively "clamping" the waveform to a desired reference level.

### Types of Clamping Circuits:

1. **Positive Clamper:** Shifts the signal upwards, clamping the most negative point of the waveform to a reference level (often 0V).
2. **Negative Clamper:** Shifts the signal downwards, clamping the most positive point of the waveform to a reference level.
3. **Biased Clamper:** Adds a specific DC bias to the signal, shifting it to a custom reference level.

The operation of a clamping circuit relies on the **charging and discharging behavior of the capacitor** and the **unidirectional conduction property of the diode**.

**During the First Half-Cycle:** When the input signal is applied, the diode conducts (if forward-biased). The capacitor charges to the peak voltage of the input signal. The resistor limits the charging current and prevents damage to the diode.

**During the Opposite Half-Cycle:** The diode becomes reverse-biased and stops conducting. The capacitor holds its charge, maintaining the stored voltage. This stored voltage is added to the input signal, shifting the waveform's DC level.

After a few cycles, the circuit reaches steady-state operation, where the capacitor maintains the voltage shift, and the diode conducts only during one half-cycle.

### Procedure:

- <https://expeyes.in/experiments/electronics/clamping.html>
- Select **Experiments > Electronics > Clamping circuit using Diode.**

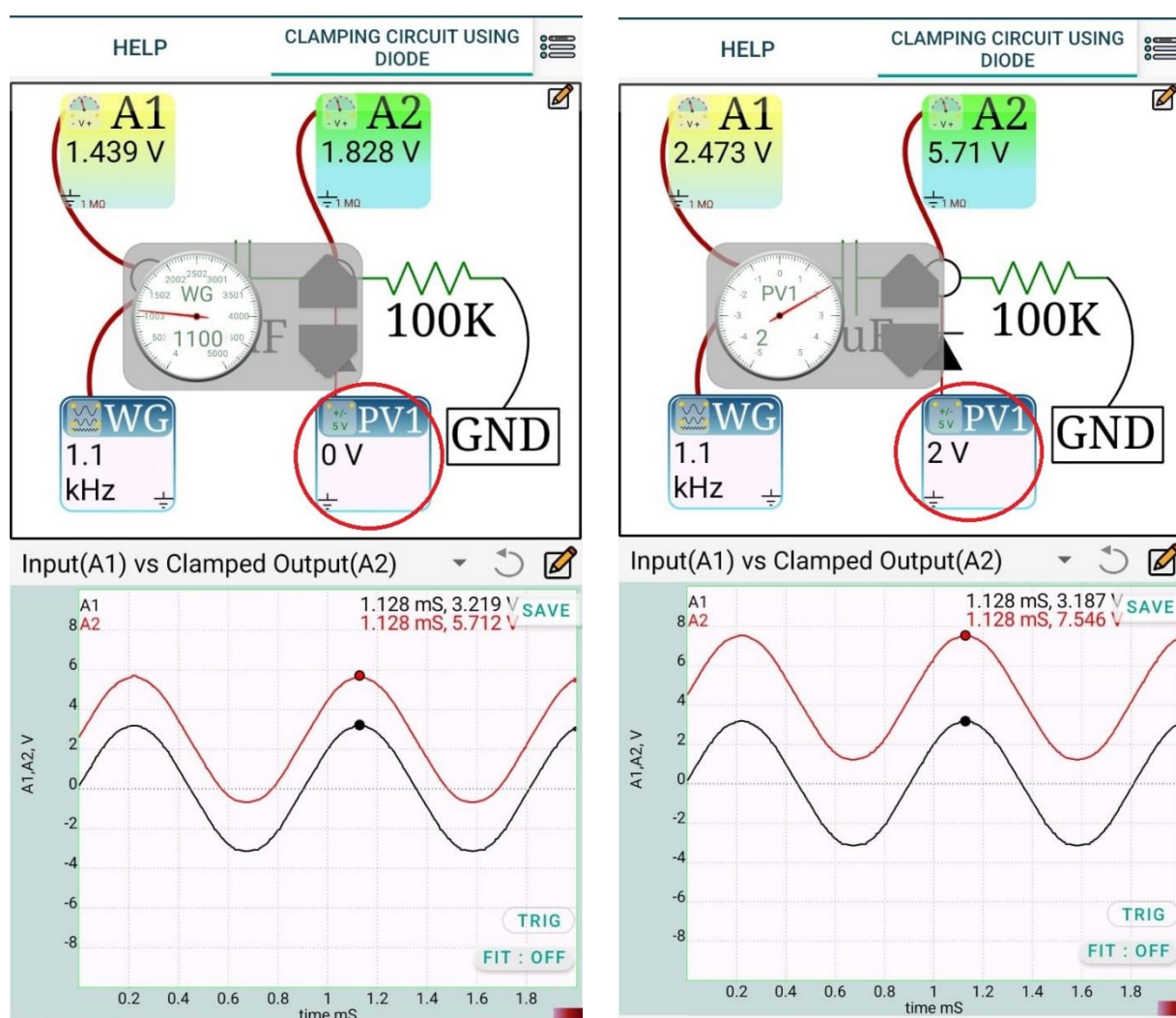

### Result

Different types of clipping and clamping circuits are realized using diodes and the waveforms are studied.